



## Electrak® HD – Technical Features



### Standard Features

- Onboard electronics with many optional functions
- Static load up to 18 kN (4050 lbf)
- Dynamic load up to 16 kN (3584 lbf)
- Stroke up to 1000 mm
- Speed up to 71 mm/s (2.8 in/s)
- Protection class static IP67 / IP69K and dynamic IP66 and tested for 500 hour salt spray resistance

### General Specifications

Screw type	ball
Nut type	load lock ball nut
Manual override	yes
Anti-rotation	yes
Static load holding brake	yes
Safety features	Electrak monitoring package: current monitoring voltage monitoring temperature monitoring load trip point calibration internal end-of-stroke limit switches <sup>(1)</sup> end-of-stroke dynamic braking
Electrical connections <sup>(2)</sup>	cable(s) with flying leads
Compliances	CE

(1) Dynamic braking is included at the ends of stroke for all Electrak HD actuators. Dynamic braking offered throughout the entire stroke length only on low-level switching and SAE J1939 options.

(2) There are one or two cables depending on the control option used. The cable(s) enters the actuator via a connector. The replacement of an actuator can be completed by unplugging the old actuator and plugging in the new one.

### Optional Mechanical Features

- Variety of front and rear adapters
- Alternative adapter orientation

### Optional Electronic Control Features

- CANopen CAN bus
- SAE J1939 CAN bus
- Synchronization option
- Low-level switching
- End-of-stroke indication output
- Analog position output
- Digital position output

### Control Option Combinations

EXX	Electrak Monitoring Package only
ELX	EXX + End-of-Stroke Indication Output
EXP	EXX + Analog Position Output
EXD	EXX + Digital Position Output
ELP	ELX + Analog Position Output
ELD	ELX + Digital Position Output
LXX	EXX + Low-Level Signal Motor Switching
LLX	EXX + LXX + End-of-Stroke Indication Output
LXP	EXX + LXX + Analog Position Output
CNO	SAE J1939 CAN Bus Control + Open-Loop Speed Control
COO	CANopen CAN Bus Control + Open-Loop Speed Control
SYN	Synchronization Option

### Accessories

- Rod end front adapter
- External slot-mounted limit switches

### Compatible Controls

Contact customer support at [www.thomsonlinear.com/cs](http://www.thomsonlinear.com/cs)

# Electrak HD – Technical Specifications

Mechanical Specifications		
Max. static load <sup>(1)</sup>	[kN (lbf)]	18 (4050)
Max. dynamic load (Fx)	[kN (lbf)]	HDxx-B017
		HDxx-B026
		HDxx-B045
		HDxx-B068
		HDxx-B100
		HDxx-B160
Speed @ no load/max. load <sup>(2)</sup>	[mm/s (in/s)]	
HDxx-B017		71/58 (2.8/2.28)
HDxx-B026		40/32 (1.6/1.3)
HDxx-B045		24/19 (0.94/0.75)
HDxx-B068		18/14 (0.71/0.55)
HDxx-B100		11/9 (0.43/0.35)
HDxx-B160		7/5 (0.27/0.21)
Min. ordering stroke (S) length	[mm]	50
Max. ordering stroke (S) length <sup>(3)</sup>	[mm]	1000
Ordering stroke length increments	[mm]	50
Operating temperature limits	[°C (F)]	-40 – 85 (-40 – 185)
Full load duty cycle @ 25 °C (77 °F)	[%]	25 <sup>(4)</sup>
End play, maximum	[mm (in)]	1.2 (0.047)
Restraining torque	[Nm (lbf-in)]	0
Protection class - static		IP67, IP69K
Protection class - dynamic		IP66
Salt spray resistance	[h]	500

(1) Max. static load at fully retracted stroke.  
 (2) For units with the synchronization option, the speed is 25% lower at any load.  
 (3) 500 mm max. for 16 kN  
 (4) For HDxx-B100 and HDxx-160, unidirectional load, the duty cycle is 15%.  
 (5) Do not use PWM voltage for speed control to avoid damaging the onboard electronics

Electrical Specifications		
Available input voltages <sup>(5)</sup>	[Vdc]	12, 24
Input voltage tolerance	[Vdc]	HD12 (12 Vdc input voltage)
		HD24 (24 Vdc input voltage)
Current draw @ no load/max. load	[A]	
HD12-B017		3/18
HD24-B017		1.5/9
HD12-B026		3/18
HD24-B026		1.5/9
HD12-B045		3/18
HD24-B045		1.5/9
HD12-B068		3/20
HD24-B068		1.5/10
HD12-B100		3/18
HD24-B100		1.5/9
HD12-B160		3/20
HD24-B160		1.5/10
Motor leads cross section	[mm <sup>2</sup> (AWG)]	2 (14)
Signal leads cross section	[mm <sup>2</sup> (AWG)]	0.5 (20)
Standard cable lengths (Ca1)	[m (in)]	0.3, 1.5, 5 (11.8, 59, 197)
Cable diameter (Ca2)	[mm (in)]	7.5 (.295)
Flying lead length (Ca3)	[mm (in)]	76 (3)
Stripped lead length (Ca4)	[mm (in)]	6 (0.25)

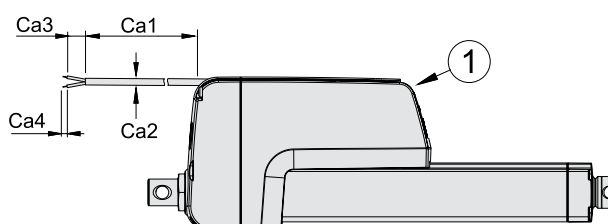

The drawing shows the cables exiting the cable slots at the end of the actuator housing, which is the shipping position. The user can adjust the exit point to be anywhere between the connector (1) in the front of the housing and the end of the cable slots.

Actuator Weight [kg]																				
Maximum Dynamic Load (Fx) [kN (lbf)]	Ordering stroke (S) [mm]																			
	50	100	150	200	250	300	350	400	450	500	550	600	650	700	750	800	850	900	950	1000
1.7 (382)	6.5	6.5	6.7	7.0	7.2	7.5	7.7	8.0	8.2	8.5	8.7	9.0	9.2	9.5	9.7	10.0	10.2	10.5	10.7	11.0
2.6 (585)	6.5	6.5	6.7	7.0	7.2	7.5	7.7	8.0	8.2	8.5	8.7	9.0	9.2	9.5	9.7	10.0	10.2	10.5	11.9	12.2
4.5 (1012)	6.5	6.5	6.7	7.0	7.2	7.5	7.7	8.0	8.2	8.5	8.7	9.0	9.2	9.5	10.7	11.0	11.3	11.6	11.9	12.2
6.8 (1592)	6.5	6.5	6.7	7.0	7.2	7.5	7.7	8.0	8.2	8.5	9.5	9.0	10.1	10.4	10.7	11.0	11.3	11.6	11.9	12.2
10 (2248)	6.7	6.7	7.0	7.2	7.5	7.7	8.0	8.2	8.5	8.7	9.7	10.0	10.3	10.6	10.9	11.2	11.5	11.8	12.1	12.4
16 (3584)	8.1	8.1	8.3	8.5	8.7	8.9	9.1	9.3	9.5	9.7	-	-	-	-	-	-	-	-	-	-

Conversion Factors: Millimeter to inch: 1 mm = 0.03937 in, kilogram to pound: 1 kg = 2.204623 lbf



# Electrak<sup>®</sup> HD – Dimensions

Dimensions	Projection
mm [inch]	

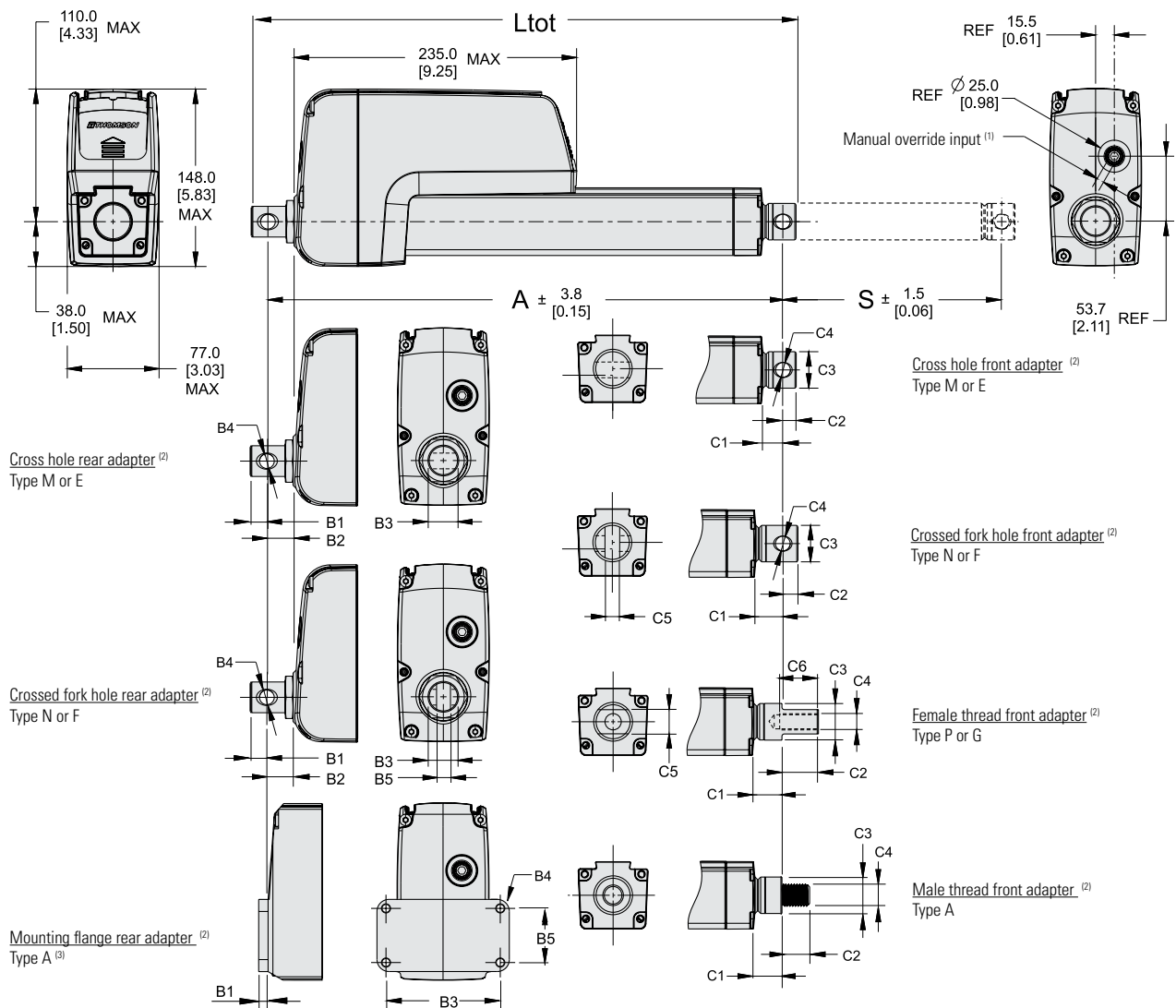

Rear and Front Adapter Dimensions [mm]

	Rear Adapter Types						Front Adapter Types						
	M	E	N	F	A <sup>(3)</sup>		M	E	N	F	P	G	A
B1	13.4	13.4	13.4	13.4	7.8	C1	see table on next page						16.5
B2	21.6	21.6	21.6	21.6	-	C2	10.9	10.9	12.9	12.9	30.0	30.0	20.0
B3	25.4	25.4	25.4	25.4	95.0	C3	see table on next page						
B4	12.2	12.8	12.2	12.8	6.6	C4	12.2	12.8	12.2	12.8	M12 × 1.75	1/2-20 UNF-2B	M16 × 2
B5	-	-	8.2	8.2	45.0	C5	-	-	8.2	8.2	19.0	19.0	-
						C6	-	-	-	-	35.0	35.0	-

(1) The input hole is covered with a plastic threaded plug. When removed, a 6 mm socket can be inserted and used as a crank.

(2) All adapters shown in the standard orientation.

(3) Rear mounting flange type A cannot be ordered with a higher maximum static load capacity than 10 kN or/and a maximum stroke of 300 mm.

Electrak<sup>®</sup> HD – Dimensions

Maximum Dynamic Load and Stroke Relationships							
Maximum Dynamic Load (Fx) - kN (lbf.)	Total Length (Ltot), Retracted Length (A) and Front Adapter Dimensions [mm]	Ordering Stroke (S) [mm]					
		50 – 500 <sup>(1)</sup>	550 – 600	650 – 700	750 – 900	950 – 1000	
1.7 (382)	Ltot	A + B1 + C2					
	A	S + 150.9 + B2 + C1					
	C1	Type M, E	17.5				
		Type N, F	26.5				
		Type P, G	23.9				
C3	30.2						
2.6 (585)	Ltot	A + B1 + C2			A + B1 + C2		
	A	S + 150.9 + B2 + C1			S + 156.8 + B2 + C1		
	C1	Type M, E	17.5			24.0	
		Type N, F	26.5			27.0	
		Type P, G	23.9			24.9	
C3	30.2			35.0			
4.5 (1012)	Ltot	A + B1 + C2			A + B1 + C2		
	A	S + 150.9 + B2 + C1			S + 156.8 + B2 + C1		
	C1	Type M, E	17.5			24.0	
		Type N, F	26.5			27.0	
		Type P, G	23.9			24.9	
C3	30.2			35.0			
6.8 (1529)	Ltot	A + B1 + C2			A + B1 + C2		
	A	S + 150.9 + B2 + C1			S + 156.8 + B2 + C1		
	C1	Type M, E	17.5			24.0	
		Type N, F	26.5			27.0	
		Type P, G	23.9			24.9	
C3	30.2			35.0			
10 (2248)	Ltot	A + B1 + C2	A + B1 + C2				
	A	S + 180.9 + B2 + C1	S + 182 + B2 + C1				
	C1	Type M, E	17.5	24.0			
		Type N, F	26.5	27.0			
		Type P, G	23.9	24.9			
C3	30.2	35.0					
16 (3584)	Ltot	A + B1 + C2	strokes not available for this model				
	A	S + 182 + B2 + C1					
	C1	Type M, E					24.0
		Type N, F					27.0
		Type P, G					24.9
C3	35.0						

(1) For a unit with 50 mm stroke, A and Ltot dimension are the same as for a unit with 100 mm stroke.



# Electrak® HD – Performance Diagrams

Load vs. Speed <sup>(1)</sup>

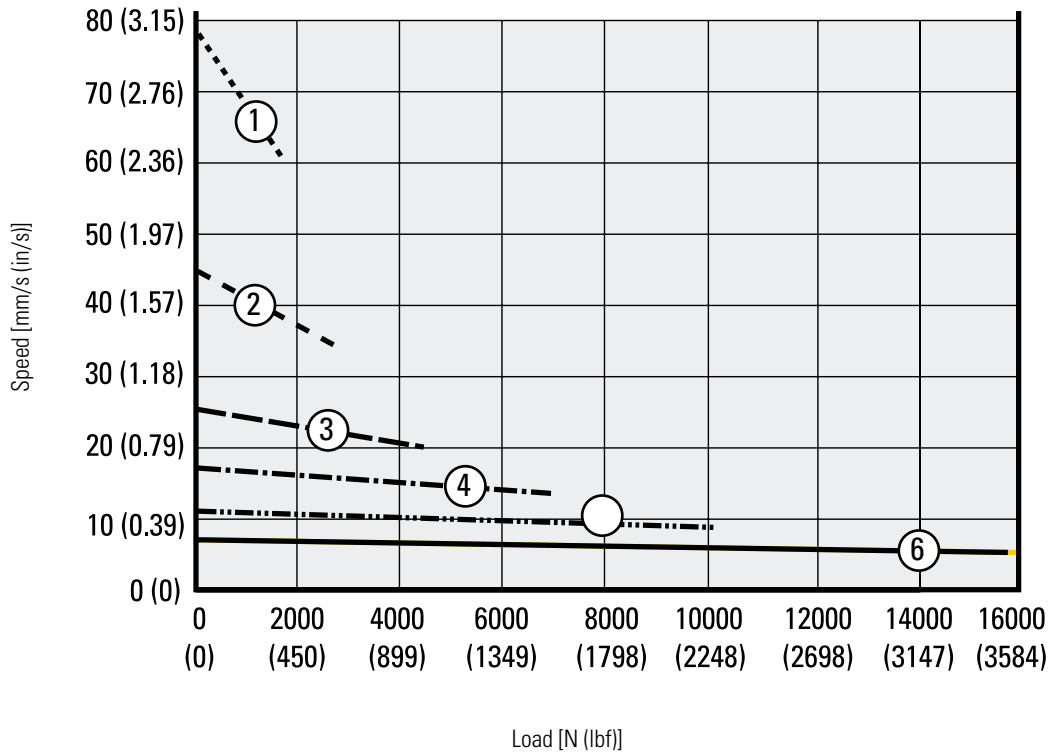

- |  |   |  |
|--|---|--|
| 1. HDxxB017 (1.7 kN (382 lbf)) - - - - - | 3. HDxxB045 (4.5 kN (1012 lbf)) - - - - - | 5. HDxxB100 (10 kN (2248 lbf)) - - - - - |
| 2. HDxxB026 (2.6 kN (585 lbf)) - - - - - | 4. HDxxB068 (6.8 kN (1529 lbf)) - - - - - | 6. HDxxB160 (16 kN (3584 lbf)) - - - - - |

<sup>1</sup> Curves valid for all units except those with the synchronization option, where the speed at any load is 25% lower than for those without.

**Note!** Curves were generated at an ambient temperature of 21°C (70°F). Different ambient temperature and individual actuator characteristics can produce slightly different values.

# Electrak® HD – Performance Diagrams

Load vs. Current

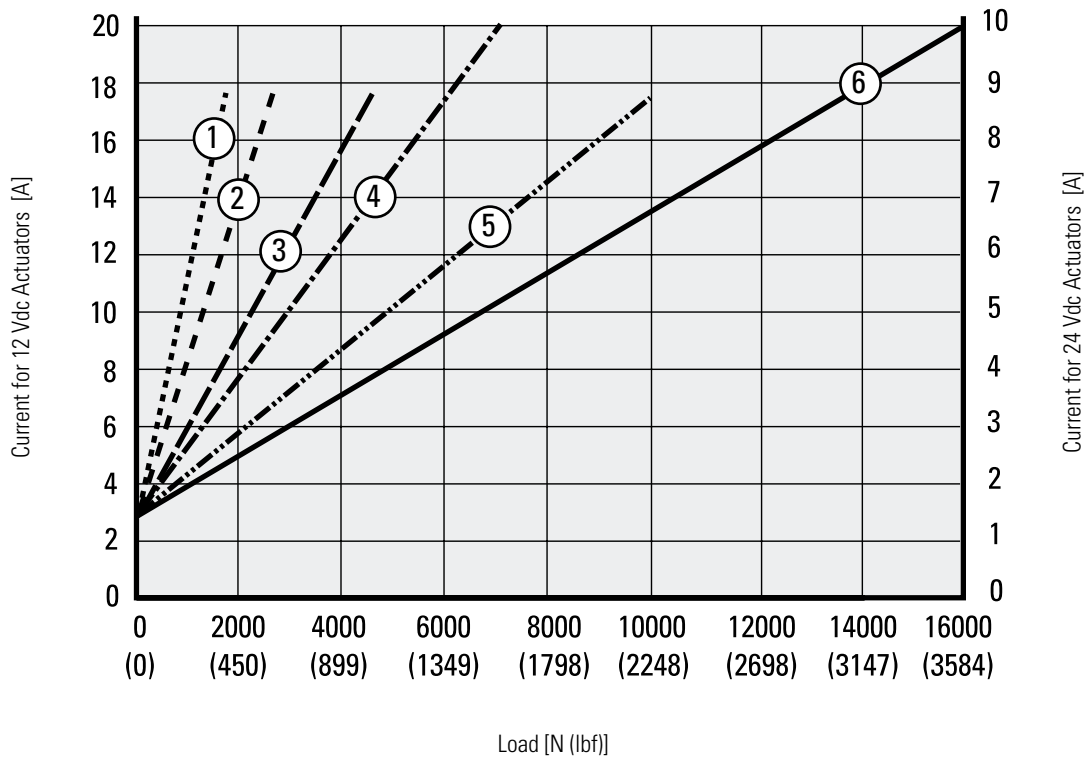

- |                                |         |                                 |             |                                |       |
|--------------------------------|---------|---------------------------------|-------------|--------------------------------|-------|
| 1. HDxxB017 (1.7 kN (382 lbf)) | .....   | 3. HDxxB045 (4.5 kN (1012 lbf)) | ----        | 5. HDxxB100 (10 kN (2248 lbf)) | ..... |
| 2. HDxxB026 (2.6 kN (585 lbf)) | - - - - | 4. HDxxB068 (6.8 kN (1529 lbf)) | - . - . - . | 6. HDxxB160 (16 kN (3584 lbf)) | ————  |

**Note!** Curves were generated at an ambient temperature of 21°C (70°F). Different ambient temperature and individual actuator characteristics can produce slightly different values.

## Electrak® HD – Ordering Key

Ordering Key								
1	2	3	4	5	6	7	8	9
<b>HD12</b>	<b>B026-</b>	<b>0300</b>	<b>LXX</b>	<b>2</b>	<b>M</b>	<b>M</b>	<b>S</b>	<b>D</b>
<b>1. Model and input voltage</b> HD12 = Electrak HD, 12 Vdc HD24 = Electrak HD, 24 Vdc  <b>2. Screw type, dynamic load capacity</b> B017- = ball screw, 1.7 kN (382 lbf) B026- = ball screw, 2.6 kN (585 lbf) B045- = ball screw, 4.5 kN (1012 lbf) B068- = ball screw, 6.8 kN (1529 lbf) B100- = ball screw, 10 kN (2248 lbf) B160- = ball screw, 16 kN (3584 lbf)  <b>3. Ordering stroke length <sup>(1) (2)</sup></b> 0050 = 50 mm <sup>(3)</sup> 0100 = 100 mm 0150 = 150 mm 0200 = 200 mm 0250 = 250 mm 0300 = 300 mm 0350 = 350 mm 0400 = 400 mm 0450 = 450 mm 0500 = 500 mm 0550 = 550 mm 0600 = 600 mm 0650 = 650 mm 0700 = 700 mm 0750 = 750 mm 0800 = 800 mm 0850 = 850 mm 0900 = 900 mm 0950 = 950 mm 1000 = 1000 mm				<b>4. Electrak Modular Control System options</b> EXX = Electronic Monitoring Package only ELX = EXX + end-of-stroke indication output EXP = EXX + analog (potentiometer) position output EXD = EXX + digital position output ELP = ELX + analog (potentiometer) position output ELD = ELX + digital position output LXX = EXX + low-level signal motor switching LLX = EXX + LXX + end-of-stroke indication output LXP = EXX + LXX + analog (potentiometer) position output CNO = SAE J1939 CAN bus + open-loop speed control COO = CANopen CAN bus + open-loop speed control SYN = LXX + synchronization option  <b>5. Cable length</b> 1 = 0.3 m long cables 2 = 1.5 m long cables 3 = 5.0 m long cables  <b>6. Rear adapter/mounting flange options</b> A = rear mounting flange <sup>(4) (5)</sup> M = cross hole for 12 mm pin E = cross hole for ½ inch pin N = forked cross hole for 12 mm pin F = forked cross hole for ½ inch pin  <b>7. Front adapter options</b> A = metric M16 male thread M = cross hole for 12 mm pin E = cross hole for ½ inch pin N = forked cross hole for 12 mm pin F = forked cross hole for ½ inch pin P = metric M12 female thread G = inch 1/2-20 UNF-2B female thread  <b>8. Adapter orientation</b> S = standard M = 90 ° turned  <b>9. Connection options</b> D = flying leads				
<p>(1) Other stroke lengths available upon request. Please contact customer support.            (2) 500 mm is the max. stroke length for 16 kN units.            (3) 50 mm stroke units will have same retracted length and envelope size as a 100 mm unit.            (4) Max. ordering stroke for the rear mounting flange type A is 300 mm.            (5) Max. dynamic load capacity for the rear mounting flange type A is 10 kN.</p>								

# Electrak® HD – Electrical Connections

Option Type EXX		
Actuator supply voltage	[Vdc]	
HD12		9 - 16
HD24		18 - 32

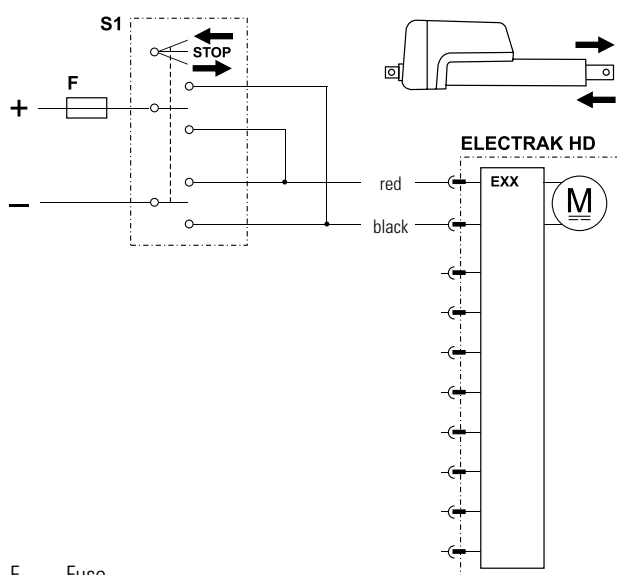

F Fuse  
S1 Double pole double throw switch

Control option EXX contains Electrak Monitoring Package features, guaranteeing safe operation of the actuator and equipment. With control option EXX, the polarity of the motor voltage is switched by a customer-supplied switch (switch, relay, etc.) to make the actuator extend or retract. The switch, power supply, wiring and all other components must be able to handle the motor current for the actuator model and load being used, as well as the inrush current (up to three times the max. continuous current for the max. load being used for up to 150 milliseconds).

Option Type ELX		
Actuator supply voltage	[Vdc]	
HD12		9 - 16
HD24		18 - 32
Output contact type		potential free
Max. output voltage	[Vdc/ac]	30/120
Max. output current	[mA]	100

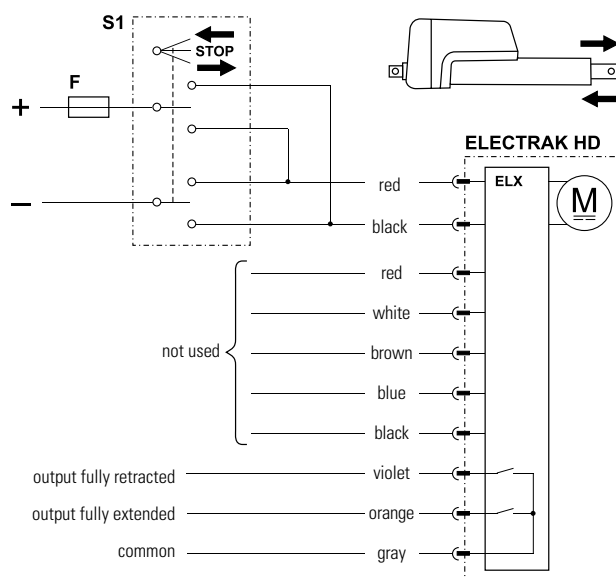

F Fuse  
S1 Double pole double throw switch

Control option ELX works as option EXX but also has two outputs that indicate when the extension tube is in its fully extended or retracted position.





# Electrak<sup>®</sup> HD – Electrical Connections

Option Type EXP		
Actuator supply voltage	[Vdc]	
HD12		9 - 16
HD24		18 - 32
Potentiometer type		wire-wound
Potentiometer max. input voltage	[Vdc]	32
Potentiometer max. power	[W]	1
Potentiometer linearity	[%]	± 0.25
Potentiometer output resolution	[ohm/mm]	
50 - 100 mm stroke		65.6
150 - 250 mm stroke		32.8
300 - 500 mm stroke		19.7
550 - 1000 mm stroke		9.8

Option Type EXD		
Actuator supply voltage	[Vdc]	
HD12		9 - 16
HD24		18 - 32
Encoder type		hall effect
Encoder input voltage	[Vdc]	4 - 24
Encoder output voltage levels	[Vdc]	
low (logical zero), typical / max.		0.1 / 0.25
Encoder resolution	[mm/pulse]	
HDxx-B017		0.28
HDxx-B026		0.15
HDxx-B045		0.09
HDxx-B068		0.07
HDxx-B100		0.04
HDxx-B160		0.03

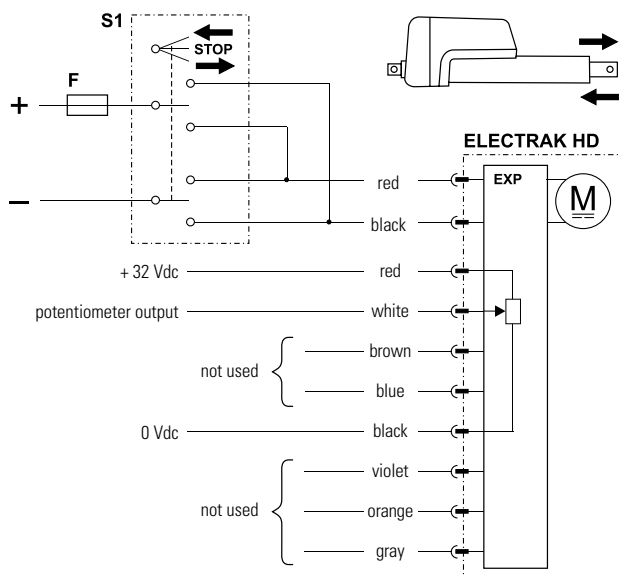

F Fuse  
S1 Double pole double throw switch

Control option EXP works as option EXX but also has an analog (potentiometer) output that will provide feedback on the extension tube position.

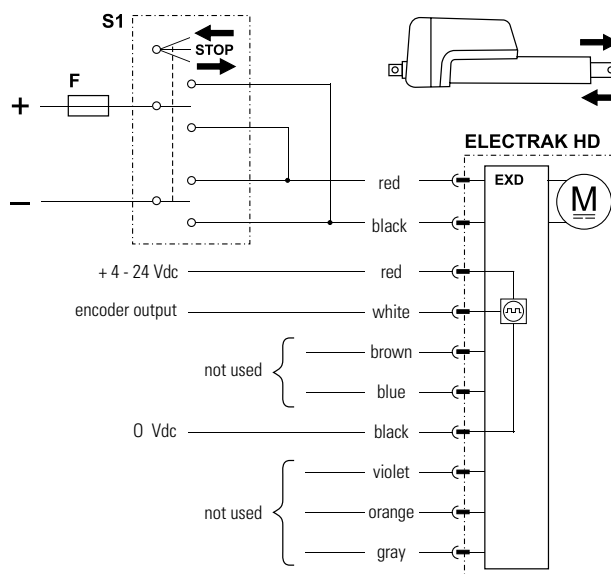

F Fuse  
S1 Double pole double throw switch

Control option EXD works as option EXX but also has a single-channel encoder output that will provide feedback on the extension tube position.

# Electrak® HD – Electrical Connections

Option Type ELP		
Actuator supply voltage	[Vdc]	
HD12		9 - 16
HD24		18 - 32
Output contact type		potential free
Max. output voltage	[Vdc/ac]	30/120
Max. output current	[mA]	100
Potentiometer type		wire-wound
Potentiometer max. input voltage	[Vdc]	32
Potentiometer max. power	[W]	1
Potentiometer linearity	[%]	± 0.25
Potentiometer output resolution	[ohm/mm]	
50 - 100 mm stroke		65.6
150 - 250 mm stroke		32.8
300 - 500 mm stroke		19.7
550 - 1000 mm stroke		9.8

Option Type ELD		
Actuator supply voltage	[Vdc]	
HD12		9 - 16
HD24		18 - 32
Output contact type		potential free
Max. output voltage	[Vdc/ac]	30/120
Max. output current	[mA]	100
Encoder type		hall effect
Encoder input voltage	[Vdc]	4 - 24
Encoder output voltage levels	[Vdc]	
low (logical zero), typical / max.		0.1 / 0.25
Encoder resolution	[mm/pulse]	
HDxx-B017		0.28
HDxx-B026		0.15
HDxx-B045		0.09
HDxx-B068		0.07
HDxx-B100		0.04
HDxx-B160		0.03

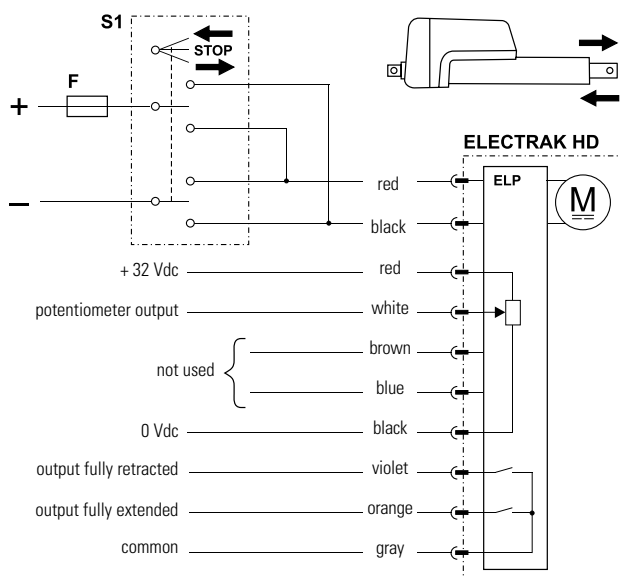

F Fuse  
S1 Double pole double throw switch

Control option ELP works as option EXP but also has two outputs that indicate when the extension tube is in its fully extended or retracted position.

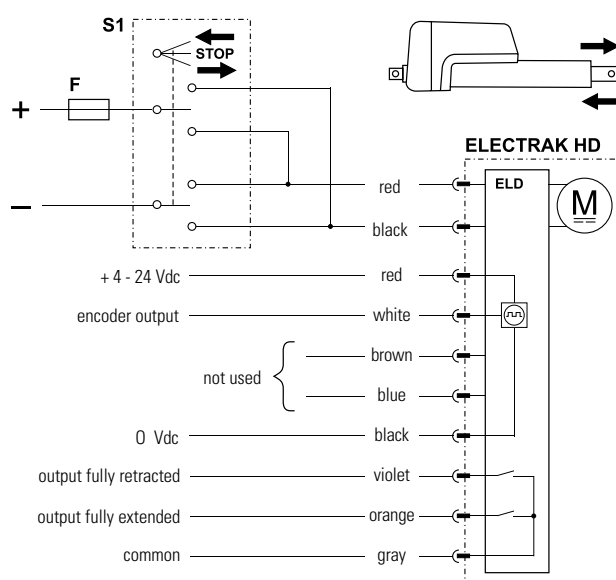

F Fuse  
S1 Double pole double throw switch

Control option ELD works as option EXD but also has two outputs that indicate when the extension tube is in its fully extended or retracted position.



# Electrak® HD – Electrical Connections

Option Type LXX		
Actuator supply voltage	[Vdc]	
HD12		9 - 16
HD24		18 - 32
Extend / retract input voltage	[Vdc]	9 - 32
Extend / retract input current	[mA]	6 - 22

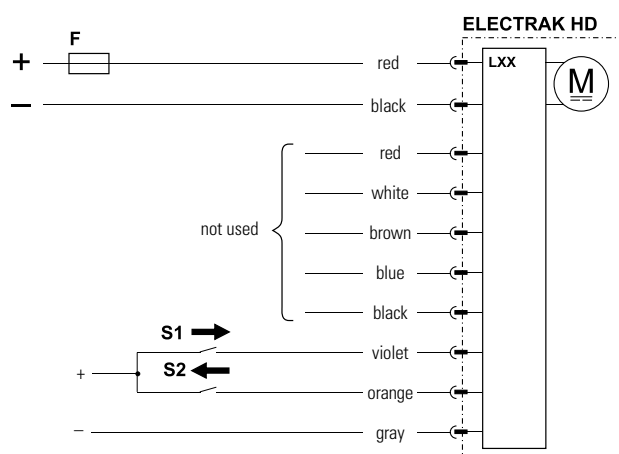
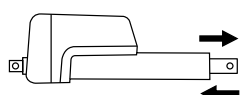

- F Fuse
- S1 Extend switch
- S2 Retract switch

Control option LXX has all the basic Electrak Monitoring Package features included in control option EXX, but the polarity of the motor voltage is switched by the onboard electronics instead. The customer-supplied switches used to command the actuator to extend or retract only need to handle low-level signals. However, the power supply and wiring that supply the actuator must be able to handle the motor current for the actuator model and load being used, as well as the inrush current (up to one and a half times the max. continuous current for the max. load being used for up to 150 milliseconds).

Option Type LLX		
Actuator supply voltage	[Vdc]	
HD12		9 - 16
HD24		18 - 32
Output contact type		potential free
Max. output voltage	[Vdc/ac]	30/120
Max. output current	[mA]	100
Extend / retract input voltage	[Vdc]	9 - 32
Extend / retract input current	[mA]	6 - 22

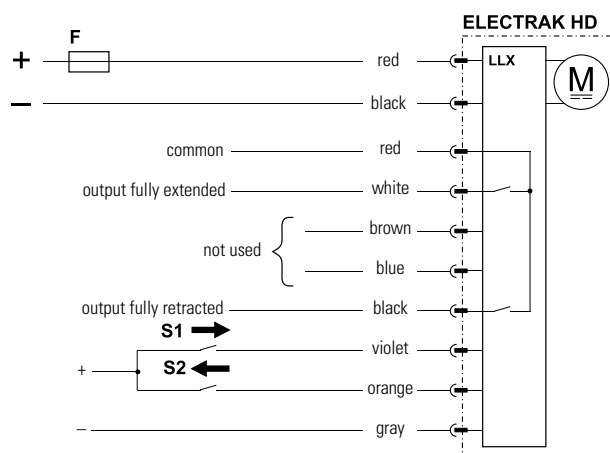
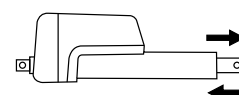

- F Fuse
- S1 Extend switch
- S2 Retract switch

Control option LLX works as option LXX but also has two outputs that indicate when the extension tube is in its fully extended or retracted position.

# Electrak® HD – Electrical Connections

Option Type LXP		
Actuator supply voltage	[Vdc]	
HD12		9 - 16
HD24		18 - 32
Potentiometer type		wire-wound
Potentiometer max. input voltage	[Vdc]	32
Potentiometer max. power	[W]	1
Potentiometer linearity	[%]	± 0.25
Potentiometer output resolution	[ohm/mm]	
50 - 100 mm stroke		65.6
150 - 250 mm stroke		32.8
300 - 500 mm stroke		19.7
550 - 1000 mm stroke		9.8
Extend / retract input voltage	[Vdc]	9 - 32
Extend / retract input current	[mA]	6 - 22

Option Type CNO and COO		
Actuator supply voltage	[Vdc]	
HD12		9 - 16
HD24		18 - 32
Command data includes:		
• position		
• speed		
• current		
Feedback data includes:		
• position		
• speed		
• current		
• other diagnostic information		

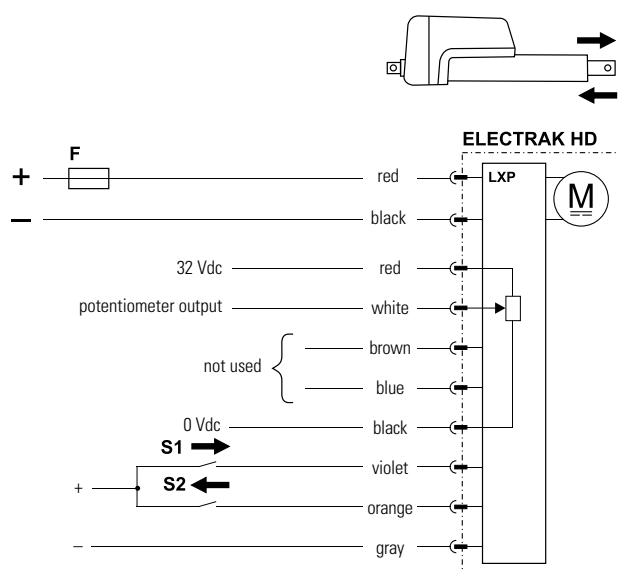
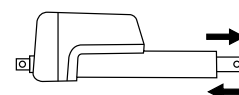

- F Fuse
- S1 Extend switch
- S2 Retract switch

Control option LXP works as option LXX but also has an analog (potentiometer) output that will provide feedback on the extension tube position.

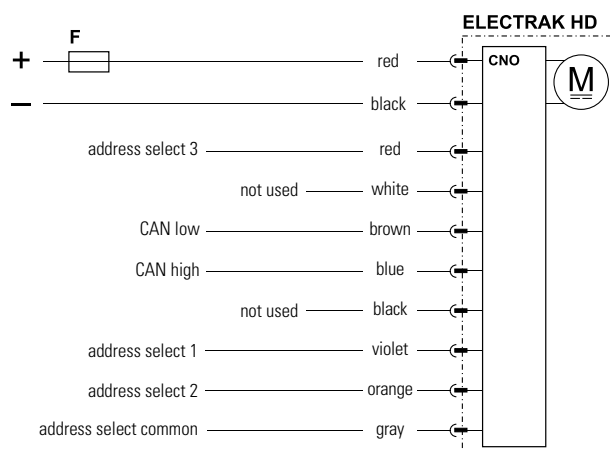

F Fuse

Control option CNO has an SAE J1939 CAN bus control interface/COO has a CANopen control interface that control and monitor the actuator. Extend and retract commands are sent via CAN messages on the CAN low and CAN high pins. Address select 1, 2 and 3 pins can be used as a BCD encoded adder to the default address. This can be used when multiple actuators are located on a single bus.



# Electrak® HD – Electrical Connections

Option Type SYN		
Actuator supply voltage	[Vdc]	
HD12		9 - 16
HD24		18 - 32
Extend / retract input voltage	[Vdc]	9 - 32
Extend / retract input current	[mA]	6 - 22
Number of synchronized actuators		2+
Max. actuator speed difference	[%]	25

Control option SYN works as option LXX but also has a synchronization feature, allowing two or more actuators having the SYN option to run in integrated motion.

When using the low-level extend and retract inputs on the master actuator, the slave(s) will follow. If there is a need to run an actuator individually, it is possible to put it into an override state by closing a switch (S3) connected to the red lead as shown in the wiring diagram.

**Important design notes:**

- Ensure that supply voltage to each actuator is within ±1.0 V.
- Uneven loading between the actuators is not recommended, but the synchronization option can withstand its effects up to a 25% speed loss.
- For units with the synchronization option, the speed at a given load is 25% lower than for those without. This is true irrespective of the unit being in synchronization or override mode, or simply run individually.
- If one actuator encounters an overload condition, it will trip the overload protection and send a signal to each actuator on the network to stop. The units can be immediately reversed (unless they bind up the system), or they can continue in the same direction after a power reset.
- If power is lost at any time to any actuator, the actuators still powered will continue their last commanded move until told to stop, either by an individual current overload trip, or a stop signal sent from the master actuator.
- If communication is lost (i.e. brown/blue wires cut), the slaves will continue their last commanded move until they reach end of stroke or trip current overload. The master will continue its last commanded move unless commanded to stop with the switching leads, reaching end of stroke, or tripping current overload.
- After a large number of mid-stroke movements, the time difference between each unit receiving a signal to move (master vs. slave) will add to small variances in when the units start and stop. Since they are designed to run at the same speed, these small differences amount to a variance of position over time – even when load is applied. To address this concern, Thomson suggests running the units either to a fully extended or fully retracted position each cycle to re-align the units with each other to take out these added variances.
- In order to give the master and slave(s) enough time to communicate there must be at least 250 ms between each start and stop command.

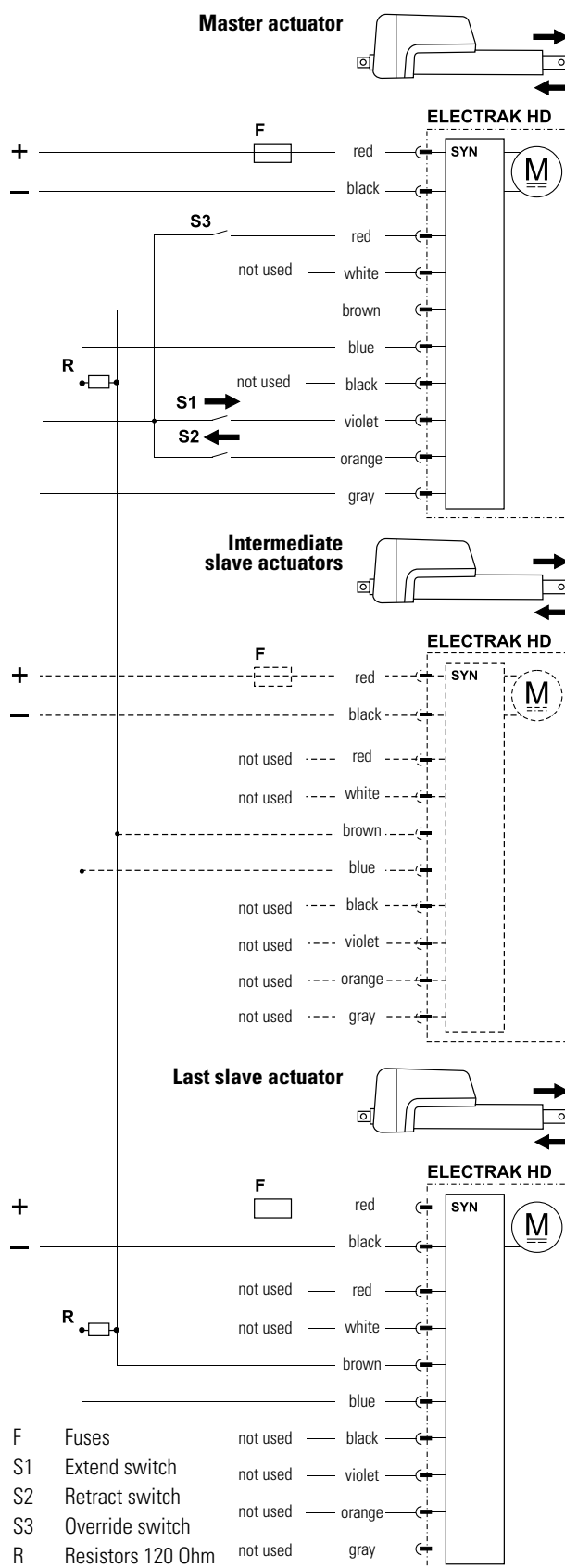

## Electrak® HD – Accessories

Limit Switches for Cover Tube Mounting			
Sensor type		solid state	reed switch
Contact type		normally open (N.O.)	
Output type		PNP	contact
Voltage	[VDC/AC]	10 - 30 / -	5 -115 / 5 -115
Max. current	[mA]	100	
Hysteresis	[mm (in)]	1.5 (0.06)	1.0 (0.04)
Operating temperature	[°C]	- 20 to + 70	- 20 to + 70
Lead cross section	[mm²]	3 × 0.14	2 × 0.14
Length (L)	[mm (in)]	25.3 (1.0)	30.5 (1.2)
Protection class		IP69K	IP67
LED indicator		yes	
Connection		2 m cable with flying leads	
p/n		840-9131	840-9132

### Mounting positions

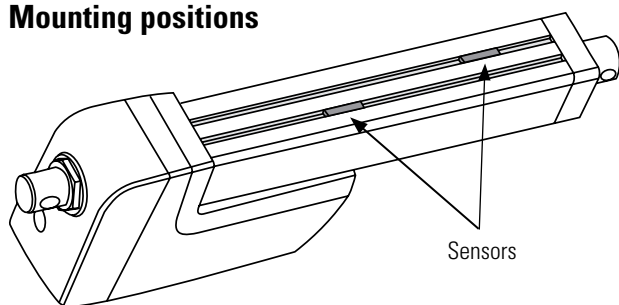

### Dimensions

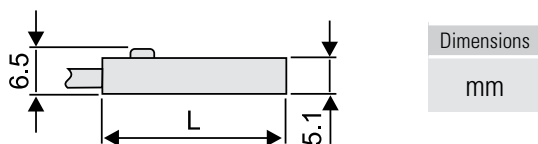

### Connection

Solid state

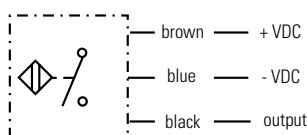

Reed switch

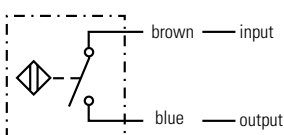

The limit switches are mounted in the cover tube slots and will be switched by a magnet mounted inside of the actuator on the extension tube.

### Rod End Front Adapter

Type	metric	inch
Material	Cadmium-plated steel	
Dimensions		
A	12.0 ± 0.1 mm	0.5 in
B	14.3 ± 0.1 mm	0.625 in
C	M12	1/2-20 UNF
p/n	756-9021	756-9007

### Dimensions

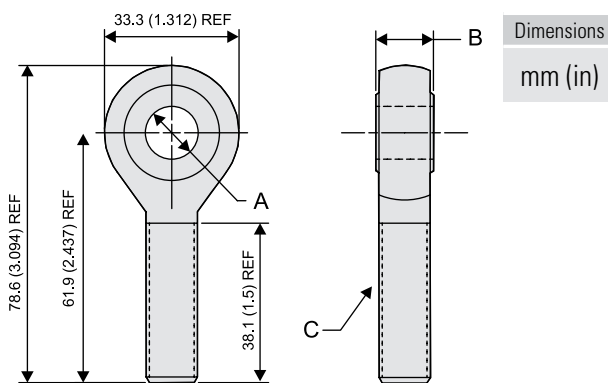

The rod end front adapter comes in one metric and one imperial version. The metric adapter can be mounted to the front of the extension tube if the actuator is equipped with the metric female thread front adapter option (type P), while the inch adapter requires the inch female thread option (type G).

### Wire Harness Kits

Part Number	Description
954-9364	0.3 m Power Only (EXX)
954-9365	1.5 m Power Only (EXX)
954-9366	5.0 m Power Only (EXX)
954-9367	0.3 m Power and 8-Wire Signal (ELX, ELP, ELD, LXX, LLX, LXP, CNO, COO, SYN)
954-9368	1.5 m Power and 8-Wire Signal (ELX, ELP, ELD, LXX, LLX, LXP, CNO, COO, SYN)
954-9369	5.0 m Power and 8-Wire Signal (ELX, ELP, ELD, LXX, LLX, LXP, CNO, COO, SYN)
954-9370	0.3 m Power and 3-Wire Signal (EXP, EXD)
954-9471	1.5 m Power and 3-Wire Signal (EXP, EXD)
954-9372	5.0 m Power and 3-Wire Signal (EXP, EXD)